

Lightweight, Compact Rotary Pneumatic Vibrators

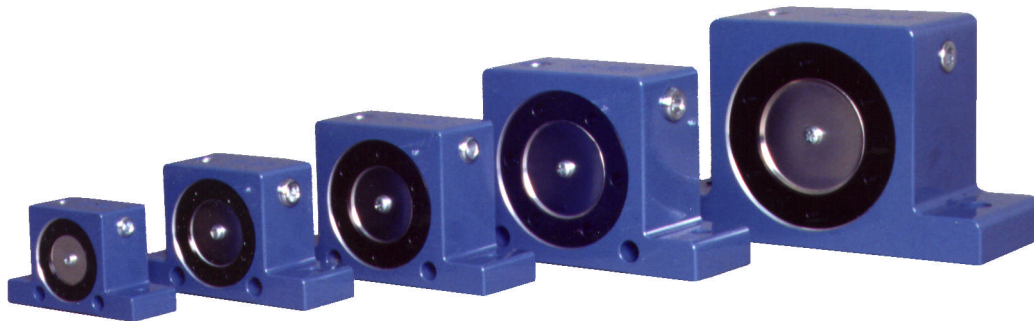

R Series Pneumatic Roller Vibrators are durable, compact, lightweight, and simple in design, and are capable of delivering very high centrifugal forces.

R Series construction features a lightweight machined aluminum body, precision steel roller, and special high impact plastic endplates. For easy mounting, the body has two sets of mounting holes*; one set for horizontal mounting, the other for vertical mounting. Air is supplied to the unit through one of two inlet ports, which are drilled at right angles to one another in the body. This design feature allows easy access to air inlets in various mounting positions.

Inlet ports are tapped with a standard pipe thread, and a pipe plug is provided for sealing the unused inlet. Air is exhausted through an air silencer incorporated into the design of the end plates.

R Series Vibrators provide a new approach to the movement of fine materials, and are ideal for many applications, including emptying hoppers, agitating small particles, moving fine powders, and compacting plastic and concrete in molds.

*Model R-120 has vertical mounting holes only

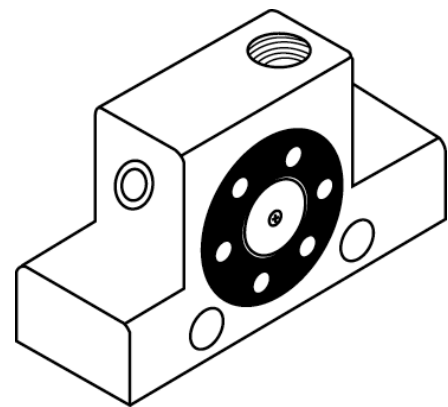

- High force output
- High frequency
- Versatile mounting
- Simple Design
- Lightweight
- Durable Construction

PERFORMANCE DATA

MODEL	FREQUENCY VPM			CENTRIFUGAL FORCE						AIR CONSUMPTION PER MINUTE					
	2 BAR	4 BAR	6 BAR	2 BAR=29 PSI		4 BAR=58 PSI		6 BAR=87 PSI		2 BAR=29 PSI		4 BAR=58 PSI		6 BAR=87 PSI	
	29 PSI	58 PSI	87 PSI	N	LB	N	LB	N	LB	LTR	CF	LTR	CF	LTR	CF
R-50	25000	35000	36000	1070	240	2920	657	4220	950	100	3.5	145	5.1	195	6.9
R-65	19000	21000	26000	2730	614	4830	1089	6120	1377	200	7.0	300	10.6	400	14.1
R-80	15500	18500	19000	3000	675	6090	1370	7450	1676	290	10.2	430	15.2	570	20.1
R-100	11000	14000	16000	3750	844	6750	1519	8900	2003	370	13.0	550	19.4	730	25.8
R-120	10000	11500	12500	8000	1800	10000	2250	12500	2812	500	17.6	730	25.8	970	34.2

Data obtained on a heavy laboratory test block. Force and frequency will decrease on a less rigid mount.

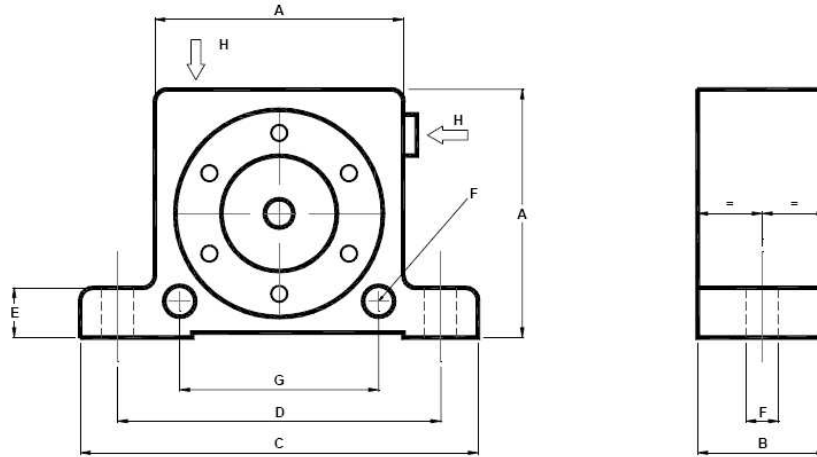

DIMENSIONAL DATA

MODEL	A		B		C		D		E		F		G		H*	Weight	
	mm	inch	mm	inch	mm	inch	mm	inch	mm	inch	mm	inch	mm	inch		BSP	kg
R-50	50	1.97	29	1.14	86	3.38	68	2.68	12	0.47	7	0.27	40	1.57	1/8"	.240	.53
R-65	65	2.56	37	1.46	113	4.45	90	3.54	16	0.63	9	0.35	50	1.97	1/4"	.545	1.20
R-80	80	3.15	43	1.69	128	5.04	104	4.09	16	0.63	9	0.35	60	2.36	1/4"	.950	2.10
R-100	100	3.94	52	2.05	160	6.30	130	5.12	20	0.79	11	0.43	80	3.15	3/8"	1.810	4.00
R-120	120	4.72	77	3.03	194	7.64	152	5.99	24	0.94	17	0.67	No lateral	3/8"		4.260	9.40

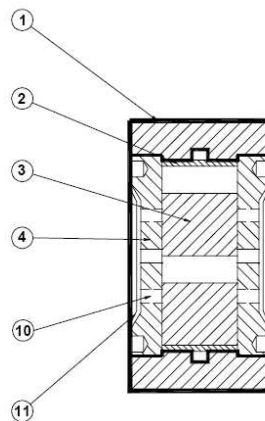
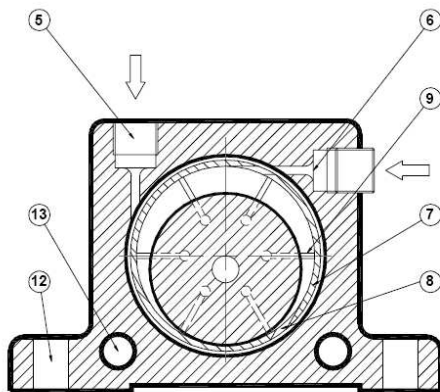

1. Extruded alloy body
2. Cast iron liner
3. Steel alloy roller
4. Plastic end plates
5. Vertical air inlet
6. Horizontal air inlet
7. Air groove
8. Inlet jets
9. Exhaust ports
10. Exhaust diffuser
11. Silencer plate
12. Base mounting holes
13. Lateral mounting holes

Ask your Houston Vibrator Salesperson for assistance in choosing the right model and mounting, control, and air prep components for your application.